

S 43 SX III

Truck-mounted concrete pump



MADE IN GERMANY
by SCHWING-Stetter 

Vertical reach		42.3 m
Concrete output	max.	162 m ³ /h
Pressure on concrete	max.	85 bar
Operating weight		< 32 t / < 70,500 lb



RECORD BREAKING ENGINEERING

SCHWING GmbH
Heerstrasse 9-27
44653 Herne, Germany
Phone +98 021 - 224 286 75-8
Fax +98 021 - 224 286 78
@mr.pump_iran
www.saghargostar-co.ir



The S 43 SX III from SCHWING

Ease without compromises

The operating weight of the S 43 SX III with completely filled tanks (fuel, water, AdBlue/DEF), complete equipment and complete operational readiness is less than 32 tons. And this with no restrictions on sturdiness, service life or resale value. Much freedom and high flexibility of use are offered by the sturdy boom in the RZ folding - not only by the 270° opening angle of the last boom element. The COC documentation delivered ex works enables all European countries to obtain quick and legal approval of the concrete pump. In operation, the S 43 SX III then exhibits the usual pattern: unrivalled low maintenance cost and excellent fuel efficiency.

The S 43 SX III from SCHWING

Advantages and benefits at a glance

Boom

Boom arms 2, 3 and 4 of the S 43 SX III feature a knuckle angle of 185°, and can be operated intuitively thanks to their roll-fold geometry. Maximum flexibility is reached by arm 5 with its Z-fold and the wide angle of 270°. The boom of the S 43 SX III is thus extremely flexible in use and also easy to operate.



Pump kit

Only the SX outriggers by SCHWING allows the longstroke pump kit P2525 with 2.50 m long pumping cylinders to be used in this class of machine. Advantage: 15% less strokes than with pump kits otherwise available in this class.



Wheelbase < 1,800 mm

Open hydraulic system

The open hydraulic system of the S 43 SX III converts the engine power efficiently into pump power with little loss. Thus, the usual practice output rates can be realized with a fuel-saving engine speed of just over 1000 rpm.



SX outriggers

The SX outriggers developed by SCHWING combines high torsional rigidity and excellent stability with minimum space requirement. The protected piston rod and internally laid hydraulic cables prevent damage and reduce service costs.



Concrete valve

The legendary low wear ROCK valve with its optimal geometry for low-friction concrete flow ensures low service and operating costs. Being fast and easy to clean, the S 43 SX III is quickly ready for the next job.



Supply control

The water box can be filled and emptied, and the water pump, agitator, spray hose, high pressure cleaner and compressor, all controlled via the standardised supply control. This is the standard for all SCHWING truck-mounted concrete pumps for greater clarity and ease of operation.



Remote control SC 30

The light weight, easy to use and comfortable SC 30 helps minimise fatigue, allowing the operator to focus on the job for extended periods. The powerful batteries guarantee an operating time of at least 8 hours.



VECTOR control

The machine operator can inspect machine data, operating conditions and settings on S 43 SX III, changing various parameters, all through the intuitive VECTOR control. The integrated diagnostic system ensures safe operation and also reminds the operator when maintenance is necessary.



S 43 SX III Truck-mounted concrete pump

Advantages and benefits in detail

The ROCK

Clean faster with less water.

Due to its straight design, in comparison to other concrete valves, the ROCK valve is easier and quicker to clean. It also provides a direct view of the pumping pistons in the delivery cylinder. The pump kit can therefore be cleaned easily and conveniently within just two strokes. This saves water and reduces the time needed for cleaning.

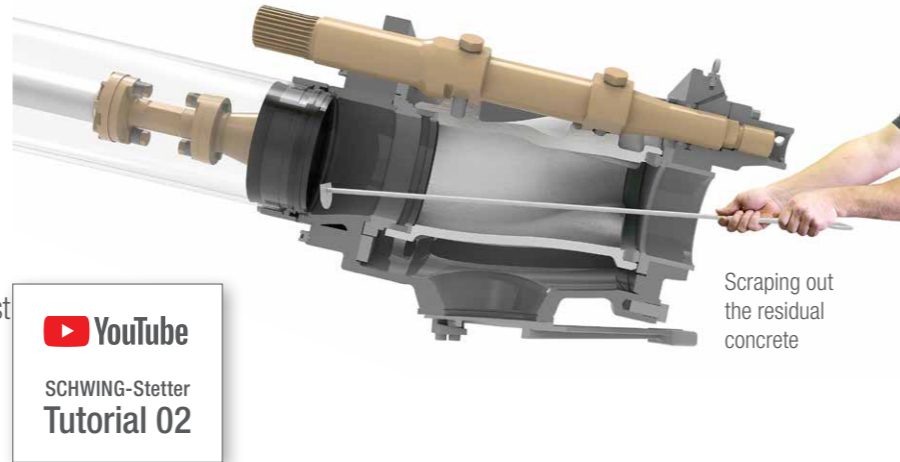

Intelligent wear protection.

The wear in the concrete valve is particularly high as the concrete is fed into the outlet at high pressure. In order to minimize this wear, at the most heavily loaded point of the ROCK concrete does not rub on steel, but rather on concrete. This is because the intelligent design of the ROCK leads to the formation of a concrete triangle after each shift. Protected by this concrete layer, the ROCK has a significantly longer service life than other concrete valves. For noticeably more profit per m³.



Easy maintenance.

The ROCK valve not only has a significantly longer service life than other concrete valves, it is also easier to maintain. After removing the housing cover, the wear parts are easily accessible and can be replaced quickly and safely. Time-consuming adjustment work is not required after replacement. The ROCK valve's 15 wearing parts is only half the number used in other concrete valves. The maintenance of the ROCK valve: simple, fast and safe.

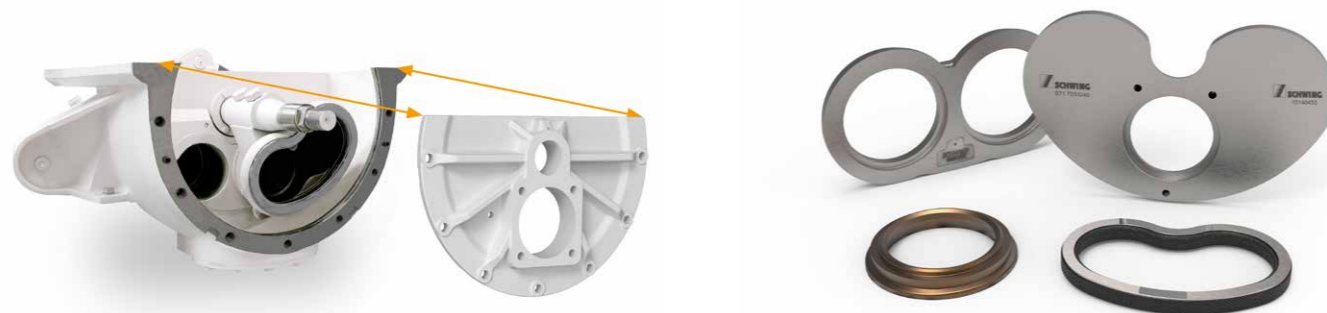

The long-stroke pump kit P2525

Less wear, more profit.

Only the SX outrigger from SCHWING enables the installation of a pump kit with 2.50 m long delivery cylinders in this class. For a standard practice delivery rate of almost 60 m³/h, the long stroke pump kit P2525 requires no more than 8 strokes per minute. The wear costs of the S 43 SX III are thus reduced to an unrivaled low level and ensure significantly more profit per m³.

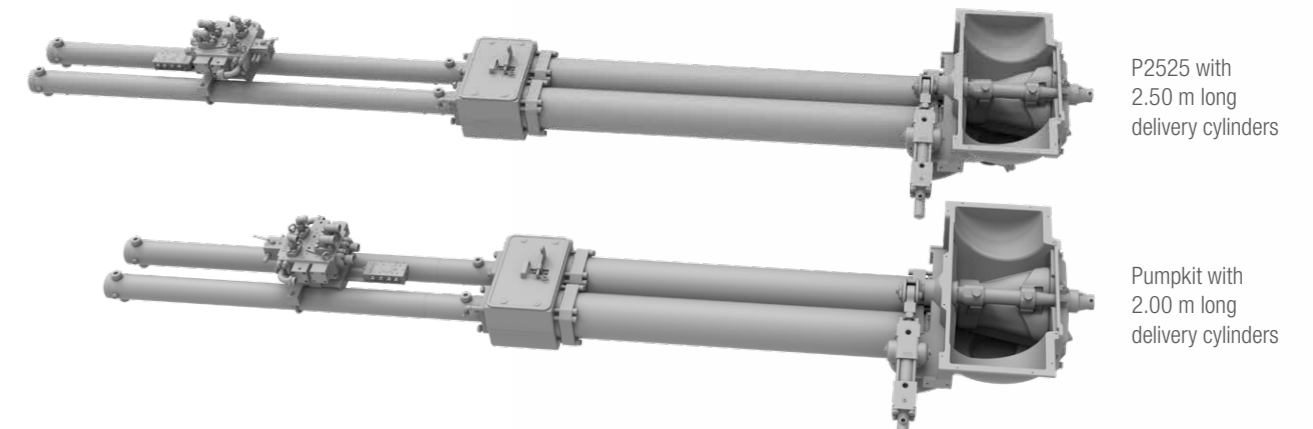

The boom

More rotation for quicker positioning.

The turret of other truck-mounted concrete pumps in this class can often only be rotated in one direction by 365°. This is not the case for the S 43 SX III from SCHWING: its turret can be rotated in both directions by 365°, thus providing significantly more flexibility and options in use.

2 x 365°

SCHWING GmbH
Heerstrasse 9-27
44653 Herne, Germany
Phone +98 021 - 224 286 75-8
Fax +98 021 - 224 286 78
@mr.pump_iran
www.saghargostar-co.ir



EASy and EASyflex

The outrigger systems EASy and EASyflex extend the range of applications of the S 43 SX III. With EASy, the concrete pump can be safely supported on one side, if required. Thereby covering a working range of 135°. EASyflex provides further outrigger combinations and as such, more flexibility on the jobsite. In this way, pump applications can be achieved with the maximum working safety even in difficult, restricted spaces. More flexibility for more safety.

EASy

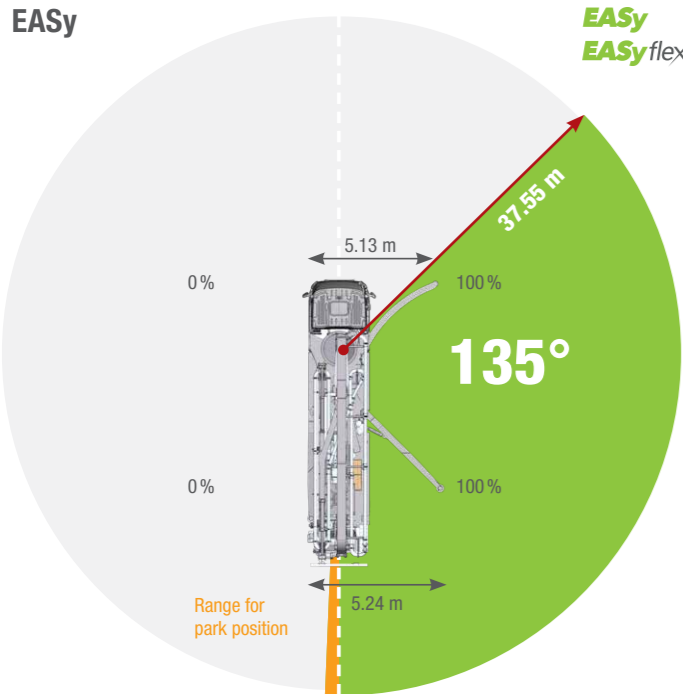

EASyExtend

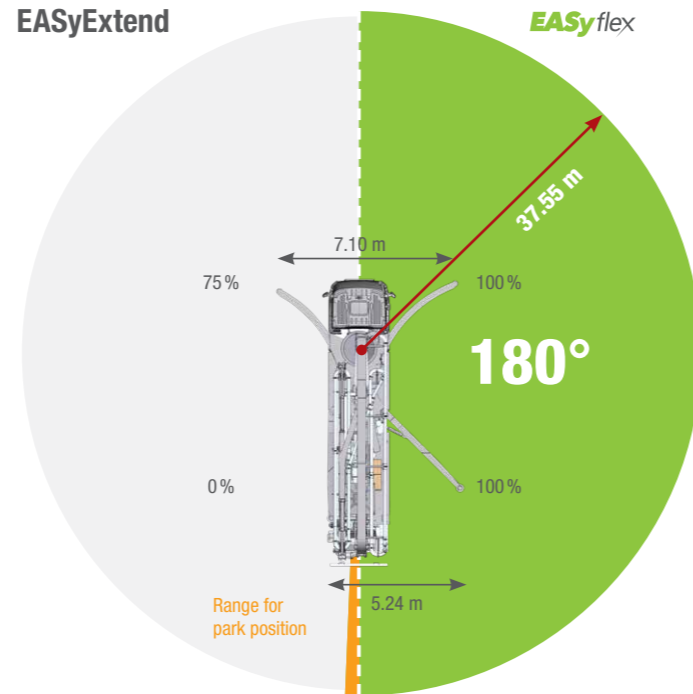

EASyFront

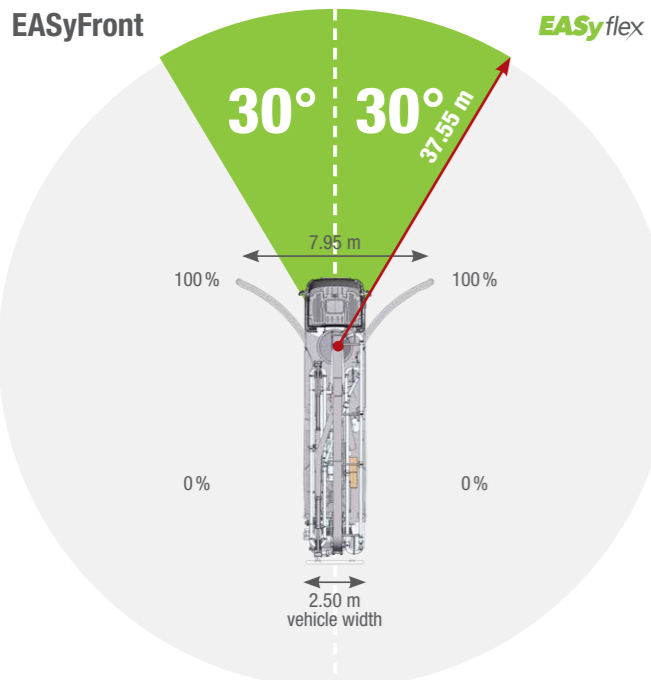

EASy with EASyFront

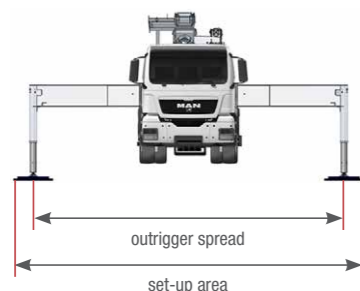
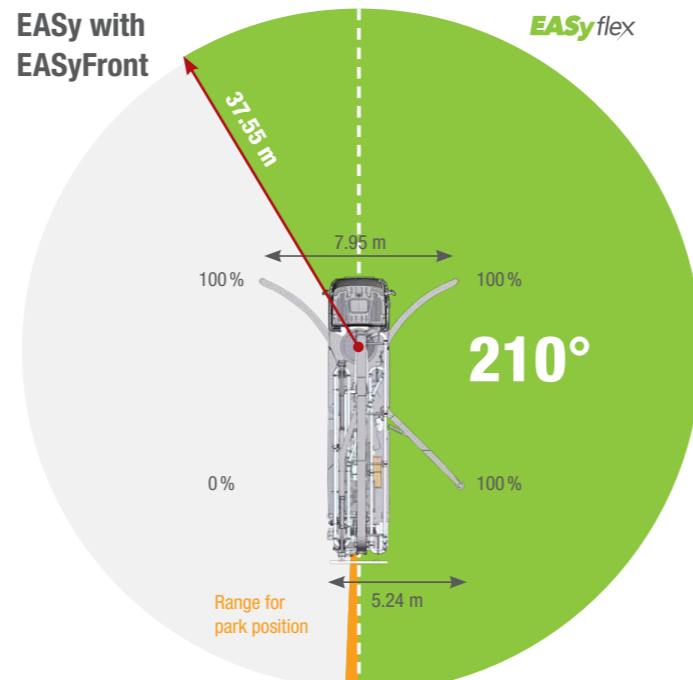

The outrigger spreads as specified are measured from the centre of the outrigger leg. Any cribbing or underlay timbers must be taken into account when determining the required set-up area.

S 43 SX III Truck-mounted concrete pump

Working range

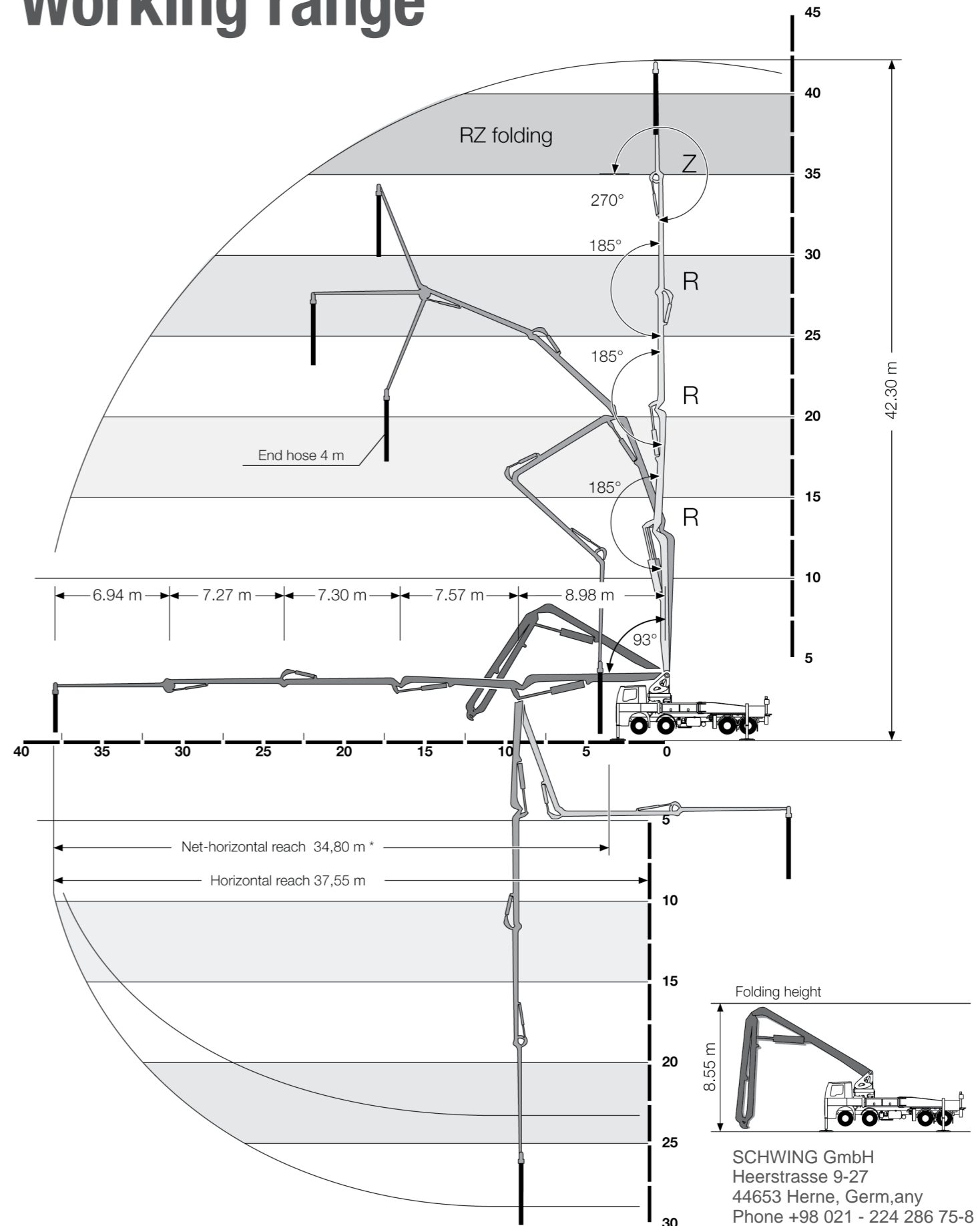

* from front of outriggers

S 43 SX III Truck-mounted concrete pump

Technical data

Performance				
Pump kit		P 2023-110/75	P 2023-110/75	P 2525-120/85
Drive	l/min	535	636	636
Delivery cylinders	mm	230 x 2,000	230 x 2,000	250 x 2,500
Concrete output max.	m ³ /h	136	161	162
Pressure on concrete max.	bar	85	85	85
Stroke rate max.	1/min.	27	32	22
Concrete valve		B-ROCK	B-ROCK	B-ROCK
Hydraulic system				
Design		offenes System		
Hydraulic tank	l	548		
Boom		43 RZ		
Delivery line		DN 125		
Length of end hose	m	4.00 (Option: 1.00 m + 3.00 m)		
Vertical reach	m	42.30		
Reach depth	m	29.90		
Horizontal reach	m	37.55		
Net horizontal reach	m	34.80 (from front of outriggers)		
Number of boom sections		5		
Height of the inflexion points	m	4.24 / 13.22 / 20.79 / 28.09 / 35.36		
Slewing range		2 x 365°		
Folding height	m	8.55		
Support				
Outrigger width, front	m	7.95		
Outrigger width, rear	m	8.30		
Outrigger load, front	kN	240		
Outrigger load, rear	kN	240		
Chassis (example s*)		Mercedes-Benz Arocs 3546	MAN TGS 35,420	
Axles configuration		8x4		
Wheelbase	mm	5,750	5,600	
Length	mm	11,800 / 11,551	11,775 / 11,526 (with / without underride guard)	
Miscellaneous				
Water tank	l	610		

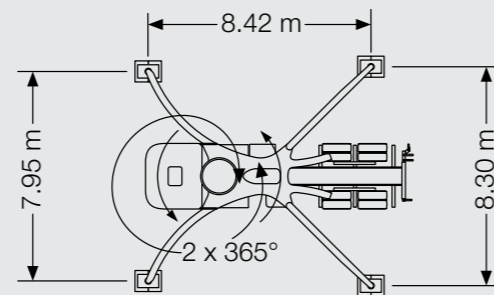

SCHWING GmbH
Heerstrasse 9-27
44653 Herne, Germany
Phone +98 021 - 224 286 75-8
Fax +98 021 - 224 286 78
@mr.pump_iran
www.saghargostar-co.ir

*other chassis possible



SCHWING concrete pumps. Efficiency as standard.



SCHWING
Stetter

SCHWING GmbH
Heerstrasse 9-27 · 44653 Herne, Germany
Phone +49 23 25 - 987-0 · Fax +49 23 25 - 72922
www.schwing-stetter.com · info@schwing.de

SCHWING GmbH
Heerstrasse 9-27
44653 Herne, Germany
Phone +98 021 - 224 286 75-8
Fax +98 021 - 224 286 78
@mr.pump_iran
www.saghargostar-co.ir

Stetter GmbH
Dr.-Karl-Lenz-Strasse 70 · 87700 Memmingen, Germany
Phone +49 83 31 - 78-0 · Fax +49 83 31 - 78 275
www.schwing-stetter.com · info@stetter.de

Subject to technical and dimensional modifications. Illustrations are non-binding. The exact standard specification, the scope of delivery and the technical data are detailed in the offer.